

Freedom™ Series

Proven Protection Made Possible By The Freedom To Design For Your Individual Application Needs

Freedom (FR) Series enclosures are developed for maximum design flexibility and pleasing aesthetics. These attractive yet highly durable enclosures fiberglass-reinforced polyester enclosures are ideal for diverse applications including: high-end electronics, OEM housings and conspicuous industrial applications, both indoors and out. They can be relied on for protection in corrosive environments where a full seal against the outside environment is critical and a watertight seal is a must.

A unique benefit of feature-laden **Freedom** Series enclosures is the internal panel management system empowering the end user to select and use only the features required for their specific application --- and to use every cubic inch of valuable internal enclosure space!

The **Freedom** Series offers an additional feature of panel mounting in the cover for use as an operator interface in industrial equipment control stations.

FREEDOM SERIES ATTRIBUTES

- Available in 2 cover options:
 1. *Opaque cover*
 2. *Flush bonded window*
- Maximum visibility to raised panels and control devices
- High temperature, flame retardant, non corrosive, environmental designs
- Stands up to an exceptionally broad range of chemical exposures
- Results in an environmentally sealed, environmentally sound space
- High impact resistance
- Double insulated material No incidental electrical contact
- Solid construction in a lightweight design
- UV Resistant

FREEDOM SERIES INDUSTRY STANDARDS

UL/cUL File #	E64358
NEMA Ratings (UL508A, UL50 & UL50e)	1, 3, 3S, 4X, 12, 13
CSA Std. C22.2 File #	LR069014
IEC 60529 Ratings	IP66
UL 1741 File #	E333478
Temperature Range	(-76°F to +274°F) (-60°C to +134°C)
Window Temperature Range	(-26°F to +170°F) (-32°C to +76°C)
Flammability Rating	UL94-5V
Window Flammability Rating	UL94-HB
Self Extinguishing	Non-Halogenated, Non-flame propagating
NFPA No. 101 Flame Spread	Class A (1)
Impact Rating	IK10
Certifications	UL, CSA, CE, REACH, RoHS
Outdoor UV Exposure (UL 746C)	(f1) Rated
Chemical Resistance	See chart on page 120

Freedom (FR)



HW



HPL

Freedom | Flush Bonded Window (FRW)



HPL

Freedom | HW

HINGED, 2 COVER SCREWS



CONSTRUCTION

Material	Hot Compression Molded Fiberglass Reinforced Polyester (Thermoset)
Gasket	Poured Seamless Polyurethane Gasket
Cover Screw Material	304 Stainless Steel
Cover Screw Size	#10-32 x 1-1/4
Cover Screw Torque	20-24 in.-lbs.
Hinge Hardware	304 Stainless Steel

INDUSTRY STANDARDS

UL/cUL File #	E64358
NEMA Ratings (UL508A, UL50 & UL50e)	1, 3, 3S, 4X, 12, 13
CSA Std. C22.2 File #	LR069014
IEC 60529 Ratings	IP66
UL 1741 File #	E333478
Temperature Range	(-76°F to +274°F) (-60°C to +134°C)
Flammability Rating	UL94-5V
Self Extinguishing	Non-Halogenated, Non-flame propagating
NFPA No. 101 Flame Spread	Class A (1)
Impact Rating	IK10
Certifications	UL, CSA, CE, REACH, RoHS
Outdoor UV Exposure (UL 746C)	(f1) Rated
Chemical Resistance	See chart on page 120

ACCESSORIES

PANELS

Aluminum Back Panel	BP__A	pg. 108
Carbon Steel Back Panel	BP__CS	pg. 108

ACCESSORIES

Mounting Feet	pg. 81
Drain & Breather Vents	pg. 102
PluggIt	pg. 103
Panel Management System	pg. 76-81
All Other Accessories	Pg. 102-117

MODIFICATIONS

Custom Colors	pg. 10-11
Silk Screening	pg. 10-11
EMI/RFI Shielding	pg. 10-11
Custom Window	pg. 10-11
Custom Cutouts/Holes	pg. 10-11



CONSTRUCTION

Material	Hot Compression Molded Fiberglass Reinforced Polyester (Thermoset)
Gasket	Poured Seamless Polyurethane Gasket
Cover Screw Size	#10-32 x 1-1/4
Cover Screw Torque	20-24 in.-lbs.
Hinge and Latch Hardware	304 Stainless Steel

INDUSTRY STANDARDS

UL/cUL File #	E64358
NEMA Ratings (UL508A, UL50 & UL50e)	1, 3, 3S, 4X, 12, 13
CSA Std. C22.2 File #	LR069014
IEC 60529 Ratings	IP66
UL 1741 File #	E333478
Temperature Range	(-76°F to +274°F) (-60°C to +134°C)
Flammability Rating	UL94-5V
Self Extinguishing	Non-Halogenated, Non-flame propagating
NFPA No. 101 Flame Spread	Class A (1)
Impact Rating	IK10
Certifications	UL, CSA, CE, REACH, RoHS
Outdoor UV Exposure (UL 746C)	(f1) Rated
Chemical Resistance	See chart on page 120

ACCESSORIES

PANELS

Aluminum Back Panel	BP__A	pg. 108
Carbon Steel Back Panel	BP__CS	pg. 108

ACCESSORIES

Mounting Feet	pg. 81
Drain & Breather Vents	pg. 102
Pluggit	pg. 103
Panel Management System	pg. 76-81
All Other Accessories	Pg. 102-117

MODIFICATIONS

Custom Colors	pg. 10-11
Silk Screening	pg. 10-11
EMI/RFI Shielding	pg. 10-11
Custom Window	pg. 10-11
Custom Cutouts/Holes	pg. 10-11

Freedom | HW & HPL

TECHNICAL DRAWINGS / DIMENSIONS

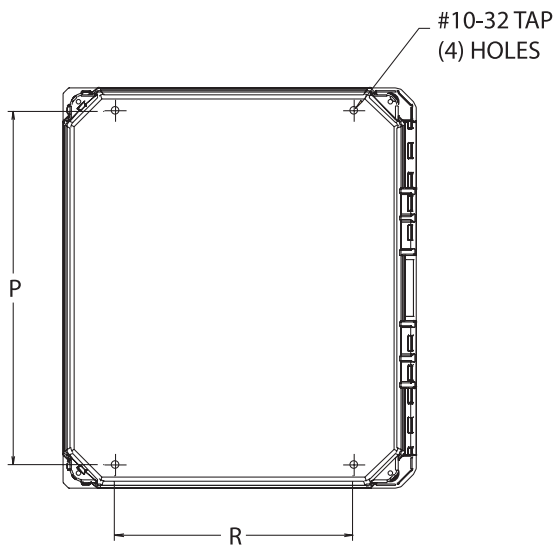

REAR VIEW

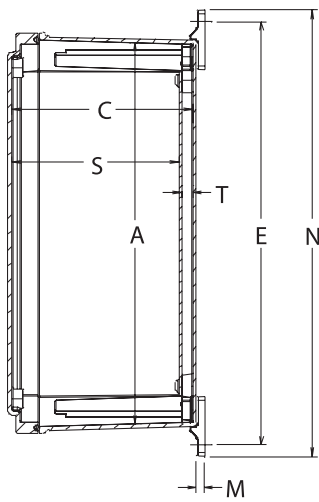
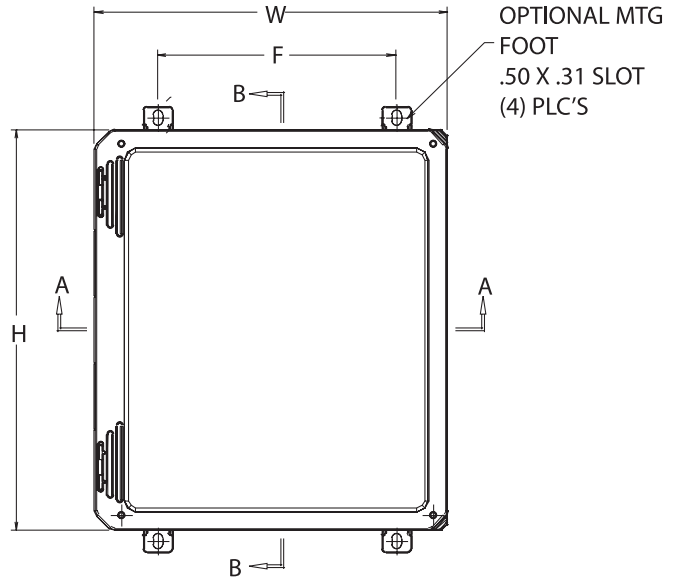

SECTION B-B

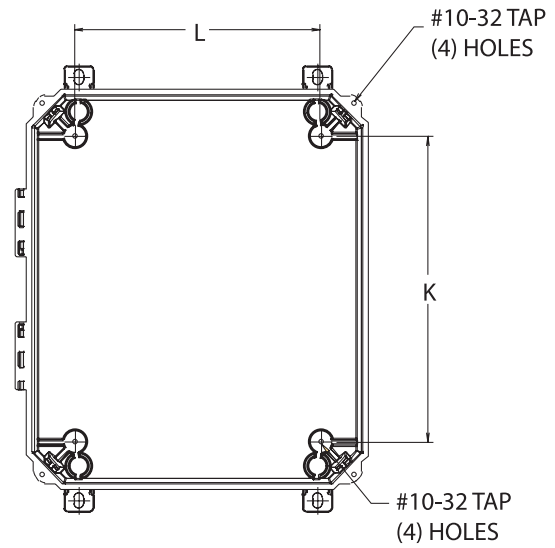

COVER
REMOVED

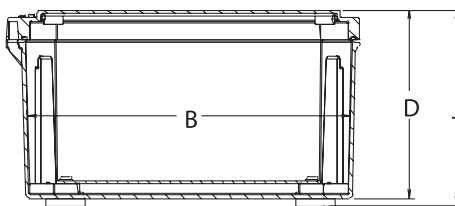

SECTION A-A

FREEDOM OPAQUE COVER SERIES ENCLOSURES

SIZE ID NUMBER	OVERALL H X W X D	INSIDE A X B X C	MOUNTING P X R	K	L	S	T	OPT. MOUNT. FEET E X F	N	J	M	SHIPPING WEIGHT	PANEL NUMBER
FR60604HW FR60604HPL	7.41 x 7.79 x 4.31 (188 x 198 x 110)	6.77 x 6.77 x 4.06 (172 x 172 x 103)	5.93 x 4.00 (151 x 102)	4.25 (108)	4.25 (108)	3.60 (92)	.38 (10)	8.24 x 4.00 (209 x 102)	9.02 (229)	4.56 (116)	.25 (6)	3.8 lbs	BP66*
FR80604HW FR80604HPL	9.41 x 7.79 x 4.31 (239 x 198 x 110)	8.77 x 6.77 x 4.06 (223 x 172 x 103)	7.91 x 4.00 (201 x 102)	6.25 (159)	4.25 (108)	3.60 (92)	.38 (10)	10.21 x 4.00 (259 x 102)	10.98 (279)	4.56 (116)	.25 (6)	4.1 lbs	BP86*
FR80804HW FR80804HPL	9.39 x 9.76 x 4.31 (239 x 248 x 109)	8.74 x 8.74 x 4.06 (222 x 222 x 103)	7.91 x 6.00 (201 x 152)	6.25 (159)	6.25 (159)	3.60 (92)	.38 (10)	10.21 x 6.00 (259 x 152)	10.98 (279)	4.56 (116)	.25 (6)	4.9 lbs	BP88*
FR100806HW FR100806HPL	11.42 x 9.79 x 6.31 (290 x 249 x 160)	10.73 x 8.73 x 6.06 (273 x 222 x 154)	9.89 x 6.00 (251 x 152)	8.25 (210)	6.25 (159)	5.60 (142)	.38 (10)	12.19 x 6.00 (310 x 152)	12.96 (329)	6.56 (167)	.25 (6)	6.2 lbs	BP108*
FR121006HW FR121006HPL	13.45 x 11.83 x 6.31 (342 x 301 x 160)	12.69 x 10.69 x 6.06 (322 x 272 x 154)	11.88 x 8.00 (302 x 203)	10.25 (260)	8.25 (210)	5.60 (142)	.38 (10)	14.18 x 8.00 (360 x 203)	14.95 (380)	6.56 (167)	.25 (6)	8.0 lbs	BP1210*
FR141206HW FR141206HPL	15.44 x 13.86 x 6.34 (392 x 352 x 161)	14.72 x 12.72 x 6.06 (374 x 323 x 154)	13.91 x 10.00 (353 x 254)	12.25 (311)	10.25 (260)	5.60 (142)	.38 (10)	16.21 x 10.00 (412 x 254)	16.98 (431)	6.59 (167)	.25 (6)	10.0 lbs	BP1412*
FR141208HW FR141208HPL	15.44 x 13.86 x 8.34 (392 x 352 x 212)	14.66 x 12.66 x 8.06 (372 x 322 x 205)	13.91 x 10.00 (353 x 254)	12.25 (311)	10.25 (260)	7.60 (193)	.38 (10)	16.19 x 10.00 (411 x 254)	16.96 (431)	8.59 (218)	.25 (6)	12.5 lbs	BP1412*
FR161408HW FR161408HPL	17.58 x 15.96 x 8.34 (447 x 405 x 212)	16.69 x 14.69 x 8.06 (424 x 373 x 205)	15.96 x 12.00 (405 x 305)	14.25 (362)	12.25 (311)	7.60 (193)	.38 (10)	18.26 x 12.00 (464 x 305)	19.04 (484)	8.59 (218)	.25 (6)	13.3 lbs	BP1614*
FR181610HW FR181610HPL	19.77 x 18.15 x 10.34 (502 x 461 x 263)	18.63 x 16.63 x 10.06 (473 x 422 x 256)	17.94 x 14.00 (456 x 356)	16.25 (413)	14.25 (362)	9.60 (244)	.38 (10)	20.24 x 14.00 (514 x 356)	21.02 (534)	10.59 (269)	.25 (6)	20.2 lbs	BP1816*
FR201610HW FR201610HPL	21.79 x 18.16 x 10.34 (554 x 461 x 263)	20.63 x 16.63 x 10.06 (524 x 422 x 256)	19.96 x 14.00 (507 x 356)	18.25 (463)	14.25 (362)	9.59 (244)	.38 (10)	22.26 x 14.00 (566 x 356)	23.04 (585)	10.59 (269)	.25 (6)	21.7 lbs	BP2016*

All measures are in inches, items in parentheses are in millimeters.

*Panel sold separately.

** Clear cover option available. Consult factory.

*** Screw down cover option available. Consult factory.

**** HLL cover option available. Consult factory.

Freedom | Flush Bonded Window | HPL

HINGED, 2 LOCKABLE PULL LATCHES



CONSTRUCTION

Material	Hot Compression Molded Fiberglass Reinforced Polyester (Thermoset)
Gasket	Poured Seamless Polyurethane Gasket
Window	Acrylic - Super Abrasion Resistant (SAR)
Hinge and Latch Hardware	304 Stainless Steel

INDUSTRY STANDARDS

UL/cUL File #	E64358
NEMA Ratings (UL508A, UL50 & UL50e)	1, 3, 3S, 4X, 12, 13
CSA Std. C22.2 File #	LR069014
IEC 60529 Ratings	IP66
UL 1741 File #	E333478
Temperature Range	(-76°F to +274°F) (-60°C to +134°C)
Window Temperature Range	(-26°F to +170°F) (-32°C to +76°C)
Flammability Rating	UL94-5V
Window Flammability Rating	UL94-HB
Self Extinguishing	Non-Halogenated, Non-flame propagating
NFPA No. 101 Flame Spread	Class A (1)
Impact Rating	IK10
Certifications	UL, CSA, CE, REACH, RoHS
Outdoor UV Exposure (UL 746C)	(f1) Rated
Chemical Resistance	See chart on page 120

ACCESSORIES

PANELS

Aluminum Back Panel	BP__A	pg. 108
Carbon Steel Back Panel	BP__CS	pg. 108

ACCESSORIES

Mounting Feet	pg. 81
Drain & Breather Vents	pg. 102
Pluggit	pg. 103
Panel Management System	pg. 76-81
All Other Accessories	Pg. 102-117

MODIFICATIONS

Custom Colors	pg. 10-11
Silk Screening	pg. 10-11
EMI/RFI Shielding	pg. 10-11
Custom Window	pg. 10-11
Custom Cutouts/Holes	pg. 10-11

Freedom | Flush Bonded Window | HPL

TECHNICAL DRAWINGS

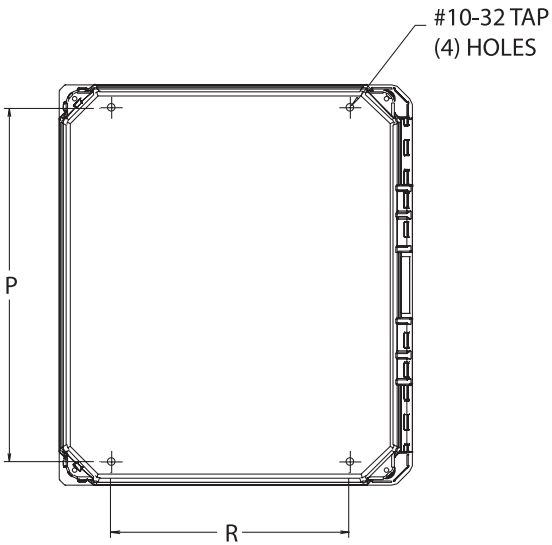

REAR VIEW

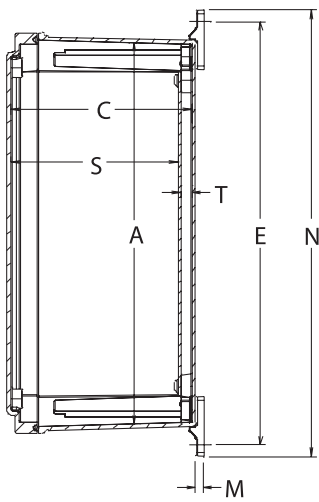
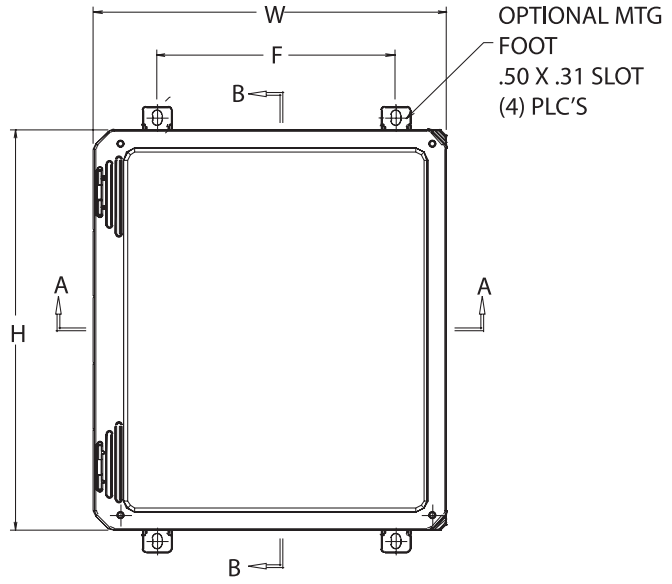

SECTION B-B

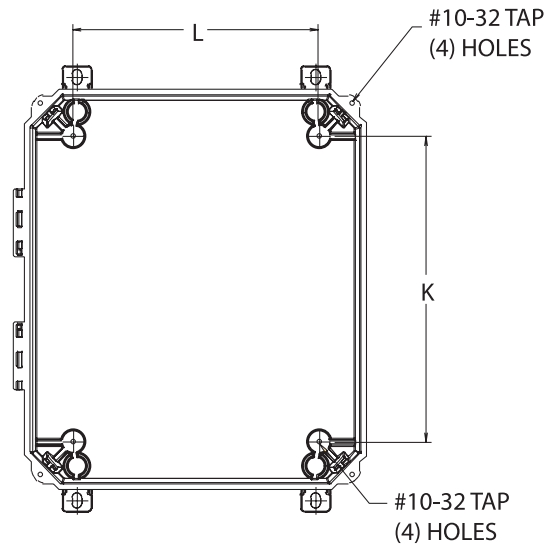

COVER
REMOVED

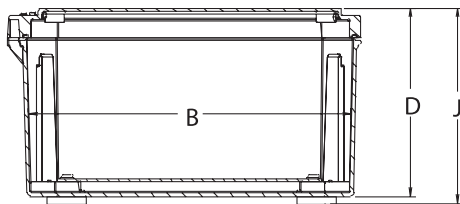

SECTION A-A

Freedom | Flush Bonded Window | HPL

DIMENSIONS

FREEDOM WINDOW SERIES ENCLOSURES

SIZE ID NUMBER	OVERALL H X W X D	INSIDE A X B X C	MOUNTING P X R	K	L	S	T	OPT. MOUNT. FEET E X F	N	J	M	SHIPPING WEIGHT	PANEL NUMBER
FRW60604HPL	7.41 x 7.79 x 4.31 (188 x 198 x 110)	6.77 x 6.77 x 4.06 (172 x 172 x 103)	5.93 x 4.00 (151 x 102)	4.25 (108)	4.25 (108)	3.60 (92)	.38 (10)	8.24 x 4.00 (209 x 102)	9.02 (229)	4.56 (116)	.25 (6)	3.8 lbs	BP66*
FRW80604HPL	9.41 x 7.79 x 4.31 (239 x 198 x 110)	8.77 x 6.77 x 4.06 (223 x 172 x 103)	7.91 x 4.00 (201 x 102)	6.25 (159)	4.25 (108)	3.60 (92)	.38 (10)	10.21 x 4.00 (259 x 102)	10.98 (279)	4.56 (116)	.25 (6)	4.1 lbs	BP86*
FRW80804HPL	9.39 x 9.76 x 4.31 (239 x 248 x 110)	8.74 x 8.74 x 4.06 (222 x 222 x 103)	7.91 x 6.00 (201 x 152)	6.25 (159)	6.25 (159)	3.60 (92)	.38 (10)	10.21 x 6.00 (259 x 152)	10.98 (279)	4.56 (116)	.25 (6)	4.9 lbs	BP88*
FRW100806HPL	11.42 x 9.79 x 6.31 (290 x 249 x 160)	10.73 x 8.73 x 6.06 (273 x 222 x 154)	9.89 x 6.00 (251 x 152)	8.25 (210)	6.25 (159)	5.60 (142)	.38 (10)	12.19 x 6.00 (310 x 152)	12.96 (329)	6.56 (167)	.25 (6)	6.2 lbs	BP108*
FRW121006HPL	13.45 x 11.83 x 6.31 (342 x 301 x 160)	12.69 x 10.69 x 6.06 (322 x 272 x 154)	11.88 x 8.00 (302 x 203)	10.25 (260)	8.25 (210)	5.60 (142)	.38 (10)	14.18 x 8.00 (360 x 203)	14.95 (380)	6.56 (167)	.25 (6)	8.0 lbs	BP1210*
FRW141206HPL	15.49 x 13.86 x 6.34 (393 x 352 x 161)	14.72 x 12.72 x 6.06 (374 x 323 x 154)	13.91 x 10.00 (353 x 254)	12.25 (311)	10.25 (260)	5.60 (142)	.38 (10)	16.21 x 10.00 (412 x 254)	16.98 (431)	6.59 (167)	.25 (6)	10.0 lbs	BP1412*
FRW141208HPL	15.49 x 13.86 x 8.34 (393 x 352 x 212)	14.66 x 12.66 x 8.06 (372 x 322 x 205)	13.88 x 10.00 (353 x 254)	12.25 (311)	10.25 (260)	7.60 (193)	.38 (10)	16.19 x 10.00 (411 x 254)	16.96 (431)	8.59 (218)	.25 (6)	12.5 lbs	BP1412*
FRW161408HPL	17.58 x 15.96 x 8.34 (447 x 405 x 212)	16.69 x 14.69 x 8.06 (424 x 373 x 205)	15.96 x 12.00 (405 x 305)	14.25 (362)	12.25 (311)	7.60 (193)	.38 (10)	18.26 x 12.00 (464 x 305)	19.04 (484)	8.59 (218)	.25 (6)	13.3 lbs	BP1614*
FRW181610HPL	19.77 x 18.15 x 10.34 (502 x 461 x 263)	18.63 x 16.63 x 10.06 (473 x 422 x 256)	17.94 x 14.00 (456 x 356)	16.25 (413)	14.25 (362)	9.60 (244)	.38 (10)	20.24 x 14.00 (514 x 356)	21.02 (534)	10.59 (269)	.25 (6)	20.2 lbs	BP1816*
FRW201610HPL	21.79 x 18.16 x 10.34 (554 x 461 x 263)	20.63 x 16.63 x 10.06 (524 x 422 x 256)	19.96 x 14.00 (507 x 356)	18.25 (463)	14.25 (362)	9.59 (244)	.38 (10)	22.26 x 14.00 (566 x 356)	23.04 (585)	10.59 (269)	.25 (6)	21.7 lbs	BP2016*

All measures are in inches, items in parentheses are in millimeters.

*Panel sold separately.

Freedom | Flush Bonded Window | HPL

TECHNICAL DRAWINGS / DIMENSIONS

VIEWING WINDOW COVER (FRW)

SIZE ID NUMBER	U	V	Z
FRW60604	4.25 (107.95)	4.25 (107.95)	3.48 (88.26)
FRW80604	6.25 (158.75)	4.25 (107.95)	3.48 (88.26)
FRW80804	6.25 (158.75)	6.25 (158.75)	3.48 (88.26)
FRW100806	8.25 (209.55)	6.25 (158.75)	5.48 (139.19)
FRW121006	10.25 (260.35)	8.25 (209.55)	5.48 (139.19)
FRW141206	12.25 (311.15)	10.25 (260.35)	5.48 (139.19)
FRW141208	12.25 (311.15)	10.25 (260.35)	7.48 (189.99)
FRW161408	14.25 (361.95)	12.25 (311.15)	7.48 (189.99)
FRW181610	16.25 (412.75)	14.25 (361.95)	9.48 (240.79)
FRW201610	18.25 (463.55)	14.25 (361.95)	9.46 (240.28)

All measures are in inches, items in parentheses are in millimeters.

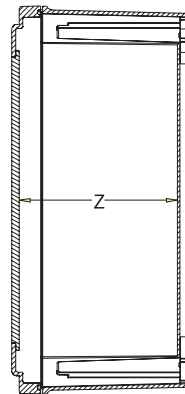
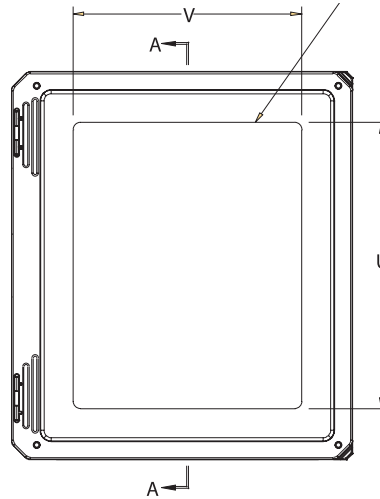

SECTION
A-A

The Design Difference... Unsurpassed Panel Management System®

AttaBox's innovative "Freedom" Panel Management System® enables Freedom users to take maximum advantage of ALL enclosure space...including the inside of the cover!

- Back Panel
- Variable Height Stationary Panel
- Variable Height Swing Panel
- Dead Front Swing Panel
- Cover Panel

The Freedom Panel Management System® Offers Many Benefits:

- Full utilization of both space and design. All space within the enclosure can be accessed and utilized with minimal requirements for additional mounting hardware.
- Panel maneuverability at both the time of assembly and in actual field use.
- Optimized use and function of all usable space within the enclosure while assisting in the mounting of cover mounted devices, such as touchpads and printed circuit boards.
- Maximized visibility of panels that offer critical feedback, such as instrumentation, while preserving the integrity of the enclosure.
- Ability to meet unique visual requirements usually associated with a dead front panel.
- Ability to meet the needs for mounting surface at rear of enclosure.
- Ability to meet end users' design capabilities and field changes that would otherwise require major modification or costly disassembly.
- Ability to externally assemble, then "drop in" to the enclosure DIN rail mounted components, thereby minimizing assembly, modification and field servicing.
- Maximum surface area for pushbutton or touchpad layout. Maximizes end users' design possibilities.
- Ability to meet end users' requirements for the installation of isolated visibility or custom visual requirements.
- Offers restricted access to areas of adjustment and calibration.

Go from This!...



...To This!



Freedom | Panel Management System

BACK PANEL



- Traditional sized back panel
- Common industry mounting footprint
- Wide choice of material

DEAD FRONT SWING PANEL



- Mounts at the front of the enclosure
- Larger surface area when compared to the variable height swing panel
- Hinged on one side, secured to the other
- Used in conjunction with corner mounting posts

VARIABLE HEIGHT STATIONARY PANEL



- Mounts at any height in the enclosure base including as back panel or use as a top stationary dead front panel
- Larger panel area than traditional back panels maximizes surface mounting area
- Used in conjunction with corner mounting posts

VARIABLE HEIGHT SWING PANEL



- Mounts at any height in the enclosure base
- Hinged on one side, secured to the other
- Used in conjunction with corner mounting posts

COVER PANEL



- Stationary panel that mounts to the inside of the enclosure cover.

USE MULTIPLE PANELS



Unique. Reliable. Flexible. Revolutionary. It's What You Want It To Be!

Just imagine ... an enclosure system that truly can be what you want...and need...it to be!
 Today, that enclosure system is a reality...with **Freedom**, from AttaBox.

The revolutionary design of **Freedom** provides a one-of-a-kind enclosure architecture that can range from "bare bones" basic yet durable simplicity to a highly customized, sophisticated protective structure.

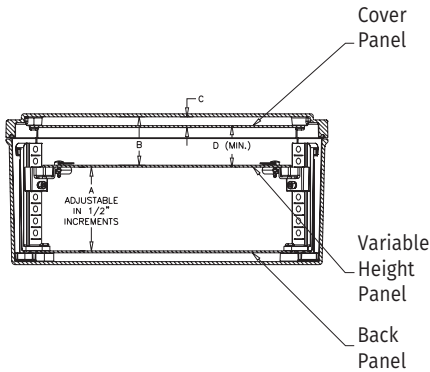

FREEDOM SERIES ENCLOSURES PANEL MANAGEMENT SYSTEM®

SIZE ID	FIXED PANEL (MIN) A	SWING PANEL (MIN) A	(MAX) A	OPAQUE/BONDED WINDOW CVR B	CLEAR CVR B	C	D (MIN)
60604	1.50 (38.1)	2.00 (50.08)	2.50 (63.50)	1.025 (26.03)	1.025 (26.03)	.375 (9.52)	.57 (14.48)
80604	1.50 (38.1)	2.00 (50.08)	2.50 (63.50)	1.025 (26.03)	1.025 (26.03)	.375 (9.52)	.57 (14.48)
80804	1.50 (38.1)	2.00 (50.08)	2.50 (63.50)	1.025 (26.03)	1.025 (26.03)	.375 (9.52)	.57 (14.48)
100806	1.50 (38.1)	2.00 (50.08)	4.50 (114.30)	1.025 (26.03)	1.025 (26.03)	.375 (9.52)	.57 (14.48)
121006	1.50 (38.1)	2.00 (50.08)	4.50 (114.30)	1.025 (26.03)	0.994 (25.24)	.375 (9.52)	.57 (14.48)
141206	1.50 (38.1)	2.00 (50.08)	4.50 (114.30)	1.025 (26.03)	0.963 (24.44)	.375 (9.52)	.57 (14.48)
141208	1.50 (38.1)	2.00 (50.08)	6.50 (165.1)	1.025 (26.03)	0.963 (24.44)	.375 (9.52)	.57 (14.48)
161408	1.50 (38.1)	2.00 (50.08)	6.50 (165.1)	1.025 (26.03)	0.963 (24.44)	.375 (9.52)	.57 (14.48)
181610	1.50 (38.1)	2.00 (50.08)	8.50 (215.90)	1.025 (26.03)	N/A	.375 (9.52)	.57 (14.48)
201610	1.50 (38.1)	2.00 (50.08)	8.50 (215.90)	1.025 (26.03)	N/A	.375 (9.52)	.57 (14.48)

Note: Swing and stationary panels adjust in 1/2" increments
 "C" not applicable for clear cover
 Cover panel kit not available for clear cover options

VARIABLE HEIGHT SWING PANEL

PART NUMBER	A	B	PANEL THK.	PANEL TYPE
P806ASA	6.38 (162)	6.56 (1167)	.080 (2)	Flat
P808ASA	6.38 (162)	8.56 (217)	.080 (2)	Flat
P1008ASA	8.38 (213)	8.56 (217)	.080 (2)	Flat
P1210ASA	10.38 (264)	10.56 (268)	.080 (2)	Flat
P1412ASA	12.38 (314)	12.56 (319)	.080 (2)	Flat
P1614ASA	14.38 (365)	14.56 (370)	.080 (2)	Flat
P1816ASA	16.38 (416)	16.56 (421)	.080 (2)	Flat
P2016ASA	18.38 (467)	16.56 (421)	.080 (2)	Flat

Caution: Metric units are for reference; do not convert.

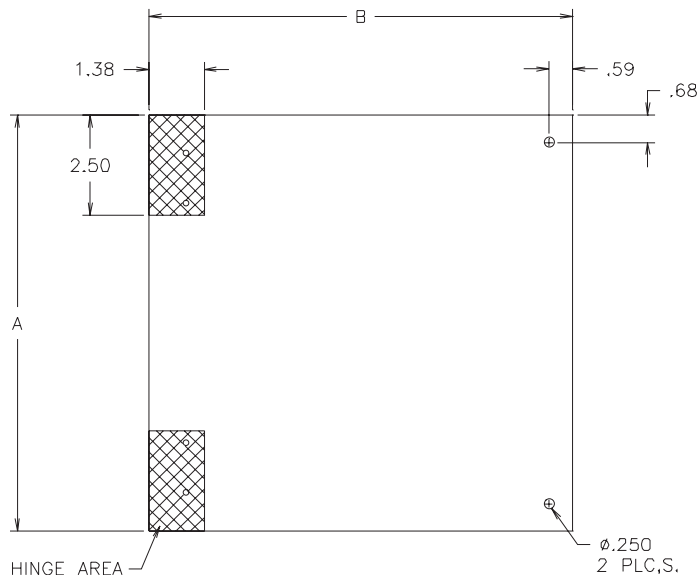

Freedom | Panel Management System

COVER PANEL DIMENSIONS

PART NUMBER	A	B	C	D	PANEL THK.	PANEL TYPE	HOLE DIA	#OF HOLES
CP606AL	5.64 (143)	5.64 (143)	5.02 (127)	5.02 (127)	.080 (2)	Flat	.25 (6)	4
CP806AL	7.68 (195)	5.64 (143)	7.05 (179)	5.02 (127)	.080 (2)	Flat	.25 (6)	4
CP808AL	7.68 (195)	7.68 (195)	7.05 (179)	7.05 (179)	.080 (2)	Flat	.25 (6)	4
CP1008AL	9.71 (247)	7.71 (196)	9.08 (231)	7.08 (180)	.080 (2)	Flat	.25 (6)	4
CP1210AL	11.74 (298)	9.74 (247)	11.12 (282)	9.12 (232)	.080 (2)	Flat	.25 (6)	4
CP1412AL	13.78 (350)	11.78 (299)	13.15 (334)	11.15 (283)	.080 (2)	Flat	.25 (6)	4
CP1614AL	15.81 (402)	13.81 (351)	15.18 (386)	13.18 (334)	.080 (2)	Flat	.25 (6)	4
CP1816AL	17.94 (456)	15.94 (405)	17.31 (440)	15.31 (389)	.080 (2)	Flat	.25 (6)	4
CP2016AL	19.76 (502)	15.76 (400)	19.13 (486)	15.13 (384)	.080 (2)	Flat	.25 (6)	4

Caution: Metric units are for reference; do not convert.

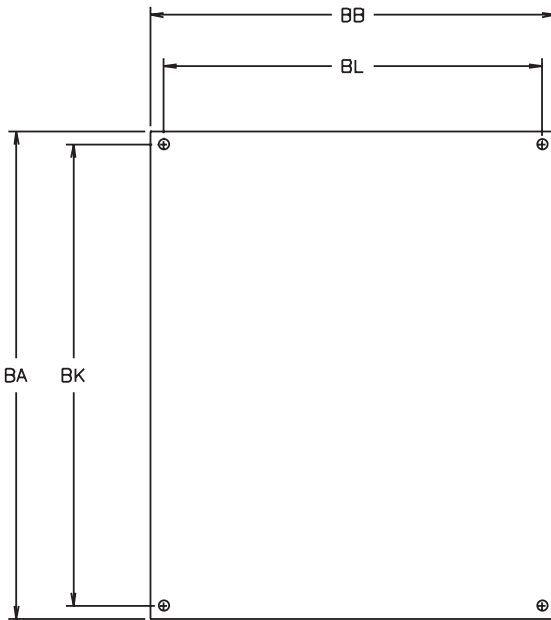
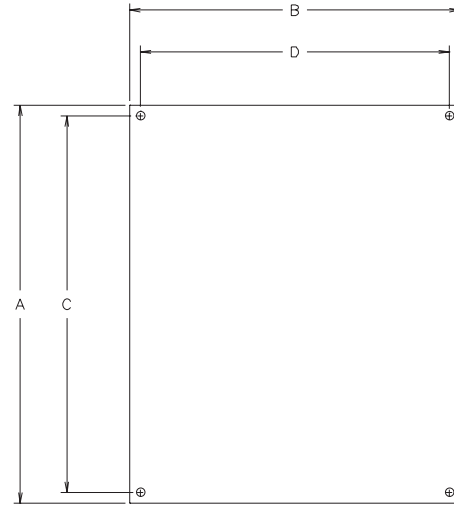

BACK PANEL DIMENSIONS

PART NUMBER	BA	BB	BK	BL	PANEL THK.	PANEL TYPE	HOLE DIA.	#OF HOLES
BP66	4.88 (124)	4.88 (124)	4.25 (108)	4.25 (108)	.080 (2)	Flat	.25 (6)	4
BP86	6.88 (175)	4.88 (124)	6.25 (159)	4.25 (108)	.080 (2)	Flat	.25 (6)	4
BP88	6.88 (175)	6.88 (175)	6.25 (159)	6.25 (159)	.080 (2)	Flat	.25 (6)	4
BP108	8.88 (225)	6.88 (175)	8.25 (210)	6.25 (159)	.080 (2)	Flat	.25 (6)	4
BP1210	10.88 (276)	8.88 (225)	10.25 (260)	8.25 (210)	.080 (2)	Flat	.25 (6)	4
BP1412	12.88 (327)	10.88 (276)	12.25 (311)	10.25 (260)	.080 (2)	Flat	.25 (6)	4
BP1614	14.88 (378)	12.88 (327)	14.25 (362)	12.25 (311)	.080 (2)	Flat	.25 (6)	4
BP1816	16.88 (429)	14.88 (378)	16.25 (413)	14.25 (362)	.080 (2)	Flat	.25 (6)	4
BP2016	18.88 (480)	14.88 (378)	18.25 (464)	14.25 (362)	.090 (2)	Flat	.25 (6)	4

Caution: Metric units are for reference; do not convert.

Suffix - Available materials

AL - Aluminum

CS - Painted Carbon Steel

Example: BP1210A

DEAD FRONT SWING PANEL DIMENSIONS

PART NUMBER	A	B	C	D	PANEL THK.	PANEL TYPE
P806SWA	8.56 (217)	6.56 (167)	5.70 (145)	6.37 (162)	.080 (2)	Flat
P808SWA	8.56 (217)	8.56 (217)	7.70 (196)	6.37 (162)	.080 (2)	Flat
P1008SWA	10.56 (268)	8.56 (217)	7.70 (196)	8.37 (213)	.080 (2)	Flat
P1210SWA	12.56 (319)	10.56 (268)	10.37 (246)	9.70 (263)	.080 (2)	Flat
P1412SWA	14.56 (370)	12.56 (319)	11.70 (297)	12.37 (314)	.080 (2)	Flat
P1614SWA	16.56 (421)	14.56 (370)	15.57 (399)	14.37 (365)	.080 (2)	Flat
P1816SWA	18.56 (471)	16.56 (421)	15.70 (399)	16.37 (467)	.080 (2)	Flat
P2016SWA	20.56 (522)	16.56 (421)	15.70 (399)	18.37 (467)	.080 (2)	Flat

Caution: Metric units are for reference; do not convert.

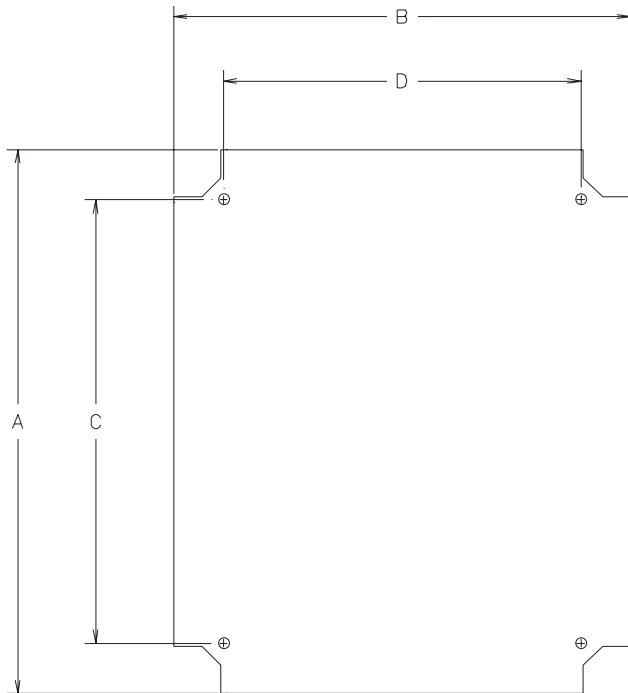
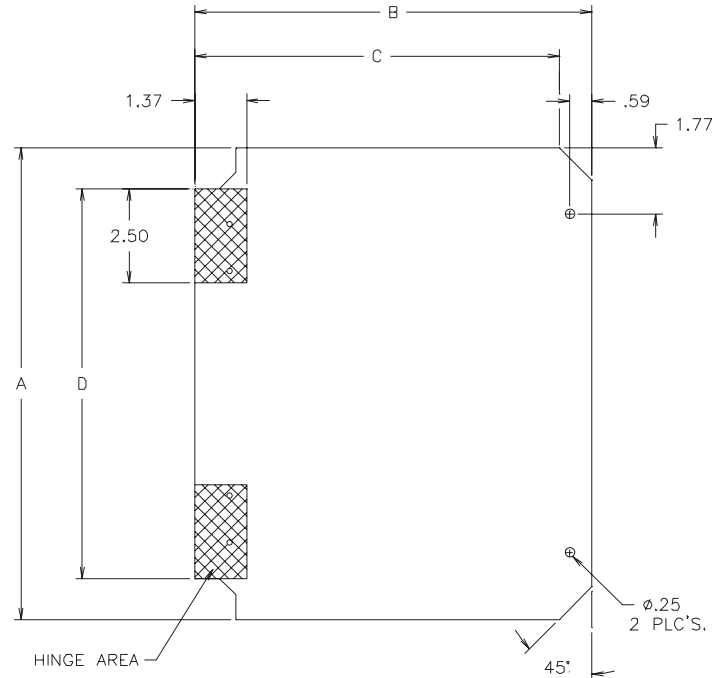

VARIABLE HEIGHT STATIONARY PANEL DIMENSIONS

PART NUMBER	A	B	C	D	PANEL THK.	PANEL TYPE	HOLE DIA.	#OF HOLES
P606STA	6.56 (167)	6.56 (167)	4.25 (108)	4.25 (108)	.080 (2)	Flat	.25 (6)	4
P806STA	8.56 (217)	6.56 (167)	6.25 (159)	4.25 (108)	.080 (2)	Flat	.25 (6)	4
P808STA	8.56 (217)	8.56 (217)	6.25 (159)	6.25 (159)	.080 (2)	Flat	.25 (6)	4
P1008STA	10.56 (268)	8.56 (217)	8.25 (210)	6.25 (159)	.080 (2)	Flat	.25 (6)	4
P1210STA	12.56 (319)	10.56 (268)	10.25 (210)	8.25 (260)	.080 (2)	Flat	.25 (6)	4
P1412STA	14.56 (370)	12.56 (319)	12.25 (311)	10.25 (260)	.080 (2)	Flat	.25 (6)	4
P1614STA	16.56 (421)	14.56 (370)	14.25 (362)	12.25 (311)	.080 (2)	Flat	.25 (6)	4
P1816STA	18.56 (471)	16.56 (421)	16.25 (413)	14.25 (362)	.080 (2)	Flat	.25 (6)	4
P2016STA	20.56 (522)	16.56 (421)	18.25 (464)	14.25 (362)	.080 (2)	Flat	.25 (6)	4

Caution: Metric units are for reference; do not convert.

Freedom | Panel Management System

PANEL KITS - ACCESSORIES ONLY, PANELS NOT INCLUDED

SIZE ID	STATIONARY PANEL ACCESSORY KIT	STATIONARY PANEL BRACKET KIT	SWING PANEL ACCESSORY KIT	SWING PANEL BRACKET KIT	CORNER POST KIT
60604	FR4PKA	FRAPBKT	N/A	N/A	FR4POST
80604	FR4PKA	FRAPBKT	FR4SPKA	FRSPBKT	FR4POST
80804	FR4PKA	FRAPBKT	FR4SPKA	FRSPBKT	FR4POST
100806	FR6PKA	FRAPBKT	FR6SPKA	FRSPBKT	FR6POST
121006	FR6PKA	FRAPBKT	FR6SPKA	FRSPBKT	FR6POST
141206	FR6PKA	FRAPBKT	FR6SPKA	FRSPBKT	FR6POST
141208	FR8PKA	FRAPBKT	FR8SPKA	FRSPBKT	FR8POST
161408	FR8PKA	FRAPBKT	FR8SPKA	FRSPBKT	FR8POST
181610	FR10PKA	FRAPBKT	FR10SPKA	FRSPBKT	FR10POST
201610	FR10PKA	FRAPBKT	FR10SPKA	FRSPBKT	FR10POST

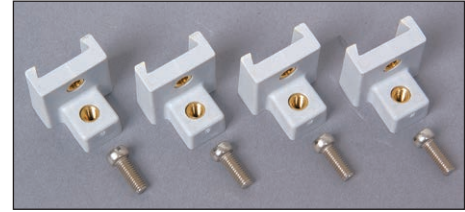

Stationary Panel Bracket Kit



Swing Panel Accessory Kit



Swing Panel Bracket Kit



Corner Post Kit



Stationary Panel Accessory Kit



Dead Front Swing Panel & Swing Panel Accessory Kit

PANEL & ACCESSORY COMBINATION KITS, INCLUDES PANEL

SIZE ID	DEAD FRONT SWING PANEL & ACCESS. KIT	VARIABLE HEIGHT SWING PANEL & ACCESS. KIT	VARIABLE HEIGHT STATIONARY PNL & ACCESS. KIT	VARIABLE HEIGHT BACK PNL & ACCESS. KIT
60604	N/A	N/A	FR60604PKA	FR60604BPKA
80604	FR80604SPK	FR80604SPKA	FR80604PKA	FR80604BPKA
80804	FR80804SPK	FR80804SPKA	FR80804PKA	FR80804BPKA
100806	FR100806SPK	FR100806SPKA	FR100806PKA	FR100806BPKA
121006	FR121006SPK	FR121006SPKA	FR121006PKA	FR121006BPKA
141206	FR141206SPK	FR141206SPKA	FR141206PKA	FR141206BPKA
141208	FR141208SPK	FR141208SPKA	FR141208PKA	FR141208BPKA
161408	FR161408SPK	FR161408SPKA	FR161408PKA	FR161408BPKA
181610	FR181610SPK	FR181610SPKA	FR181610PKA	FR181610BPKA
201610	FR201610SPK	FR201610SPKA	FR201610PKA	FR201610BPKA



Variable Height Swing Panel & Swing Panel Accessory Kit



Variable Height Back Panel & Stationary Panel Accessory Kit



Variable Height Stationary Panel & Stationary Panel Accessory Kit



Mounting Feet



Cover Screw Kit

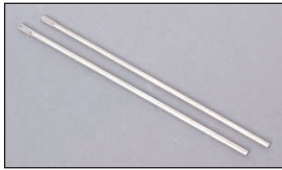

Hinge Kit

OTHER ACCESSORY KITS

SIZE ID	MTG. FOOT KIT	OPAQUE COVER SCREW KIT	PULL LATCH KIT	HINGE KIT
60604	FRMGFTKIT	FRWKIT	FRHPLKIT	FR3HINGEKIT
80604	FRMGFTKIT	FRWKIT	FRHPLKIT	FR4HINGEKIT
80804	FRMGFTKIT	FRWKIT	FRHPLKIT	FR4HINGEKIT
100806	FRMGFTKIT	FRWKIT	FRHPLKIT	FR5HINGEKIT
121006	FRMGFTKIT	FRWKIT	FRHPLKIT	FR5HINGEKIT
141206	FRMGFTKIT	FRWKIT	FRHPLKIT	FR6HINGEKIT
141208	FRMGFTKIT	FRWKIT	FRHPLKIT	FR6HINGEKIT
161408	FRMGFTKIT	FRWKIT	FRHPLKIT	FR6HINGEKIT
181610	FRMGFTKIT	FRWKIT	FRHPLKIT	FR6HINGEKIT
201610	FRMGFTKIT	FRWKIT	FRHPLKIT	FR6HINGEKIT



Lockable Pull Latch Kit

Freedom | Covers Only

OPAQUE COVERS

VIEWING WINDOW COVERS

PART NUMBER	PART NUMBER
FR606CVR	FRW606CVR
FR806CVR	FRW806CVR
FR808CVR	FRW808CVR
FR1008CVR	FRW1008CVR
FR1210CVR	FRW1210CVR
FR1412CVR	FRW1412CVR
FR1614CVR	FRW1614CVR
FR1816CVR	FRW1816CVR
FR2016CVR	FRW2016CVR